











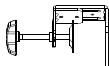







KPM-310

Introduction:

Thank you for purchasing the KPM-310 LCD/LED dual monitor mount. This product is shipped with all proper installation hardware and components. Upon opening the box, make sure that none of these parts are missing and/or damaged before beginning installation.

I. Hardware kit

Label	Image	Item	Quantity
A		VESA monitor plate	2
B		Dual mounting arm	1
C		C-clamp with locking knob	1
D		Shaft	1
E		Cable clip with tool holder	1
F		Grommet base	1
G		Thick plastic washer	2
H		Plate retaining screw	2
I		Adhesive rubber pads	5

Label	Image	Item	Quantity
J		Shaft mounting screws	3
K		Flat clamping plate	1
L		4mm allen wrench	1
M		6mm allen wrench	1
M-A		M4x12 screw	8
M-B		M4x16 screw	8
M-C		M5x12 screw	8
M-D		M5x16 screw	8
M-E		D5 metal flat washer	8
M-F		Round spacer	8

IMPORTANT:

At least two qualified people should perform the assembly procedure. Personal injury and/or property damage can result from dropping or mishandling the display.

Mounting surfaces must be sturdy and flat.

Do not install this product on a weak, uneven surface, prone to vibration or susceptible to other movements. Reinforce the structure as necessary before installing the mount.

Maximum weight supported:

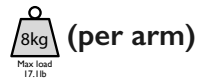

The combined weight of all components shall not exceed the rated load capacity of the mounting arm.

2. WARNING!

- Prior to installing this product, you must read all instructions thoroughly. Keep these installation instructions in an easily accessible location for future reference.
- Safety measures must be practiced at all times during the assembly of this product. Use proper safety equipment and tools for the assembly procedure to prevent personal injury.
- Klip Xtreme does not warrant against damage caused by the use of any Klip Xtreme mounts for purposes other than those for which it was designed or damage caused by unauthorized attachments or modifications, and is not responsible for any damages, claims, demands, suits, actions or causes of action of whatever kind resulting from, arising out of or in any manner relating to any such use, attachments or modifications.

3. Product diagram

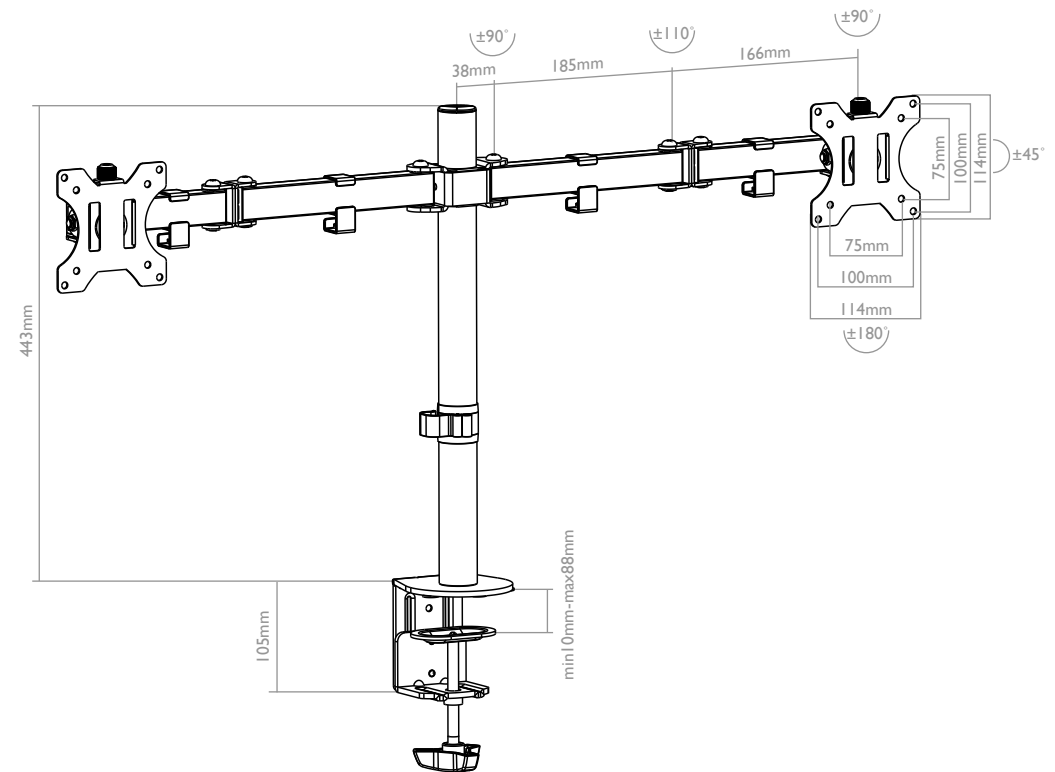

4. Installation of the monitor plate to the display

1. Carefully place your display face down on a soft, even surface, and identify the threaded mounting points that are located on the back panel.
2. Determine the correct screw size by carefully inserting a straw or toothpick, and mark the depth of the mounting point. Please note that not all the hardware included will be used.

CAUTION: Verify the adequate thread engagement of the screw/spacer combination on your monitor. Too short will not hold the display and too long will damage it.

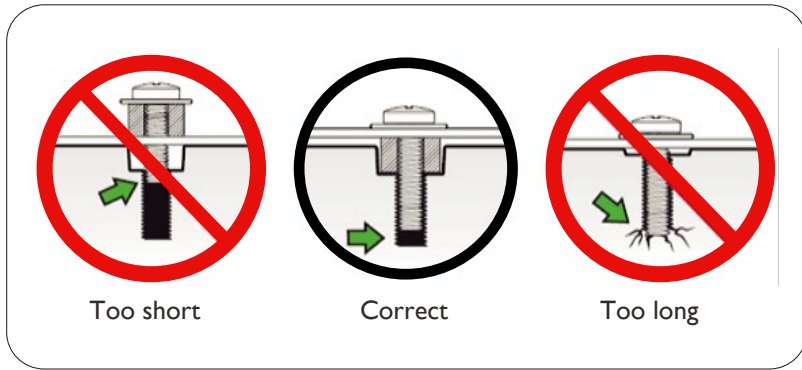

3. Attach the plate to the monitor by aligning the mounting holes in the VESA plate with the corresponding threaded inserts of the display.

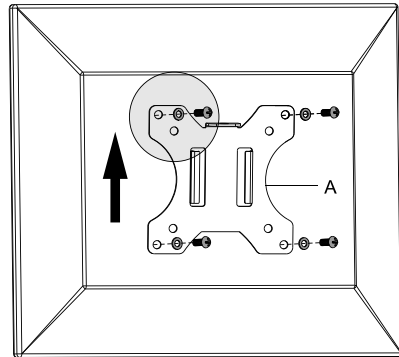
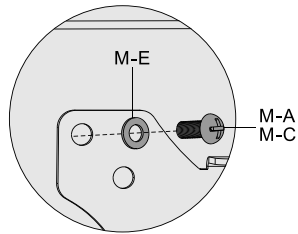
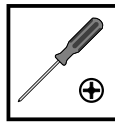
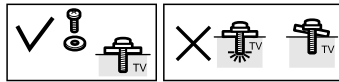
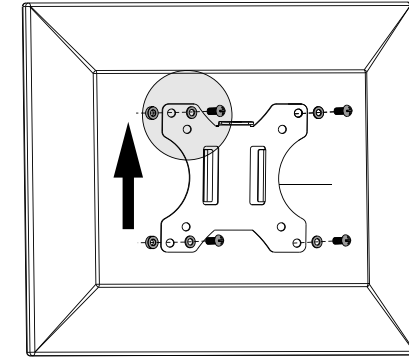
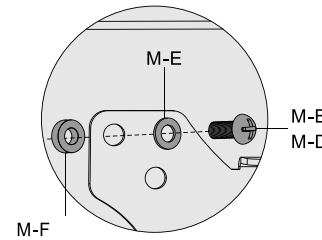
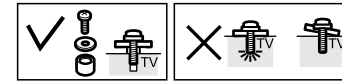

Monitor with a flush installation surface

4. If your monitor has an irregular back or recessed mounting points, spacers must be placed between the plate and the display, to compensate the difference in depth.

Monitor with a recessed installation surface

5. Use a Phillips-head screwdriver to fasten the VESA plate to the display. Be careful not to over-tighten the screws.
6. Repeat the same procedure for the second monitor.

5. Desktop installation

Notes:

- The monitor arm allows two installation configurations. It can be clamped to a desk or table, or mounted through a grommet hole. Instructions for both will be provided in the following sections.
- First, decide where you prefer to place your monitor. Prior to attaching the shaft to your desk, make sure you have enough room to fit the entire assembly either behind or in the cable hole area of your desk, depending on the mounting method you choose.

Option A - C-clamp mount

1. The clamp provides two positions depending on the thickness of your desk. For thinner surfaces, unfasten the two screws and move the base plate upwards to the next hole position. Tighten the screws when done.

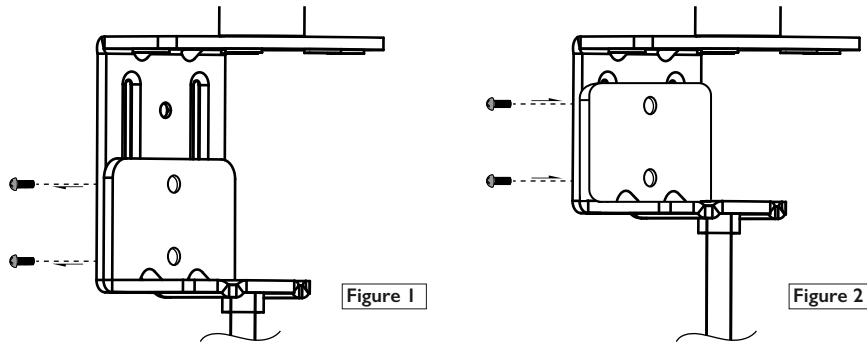

2. Proceed to attach the shaft to the C-clamp using the supplied screws, as illustrated below.

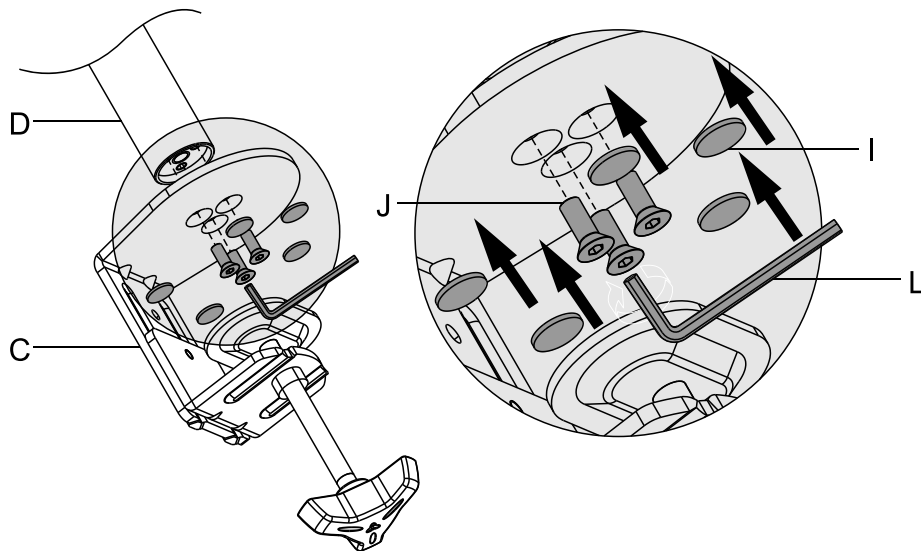

3. Tighten the screws firmly using the allen wrench, and then fix the five rubber pads underneath the top plate.
4. Slide the clamp base onto the edge of your desktop in your desired location. Tighten the locking knob until the shaft is securely mounted to your desk surface.

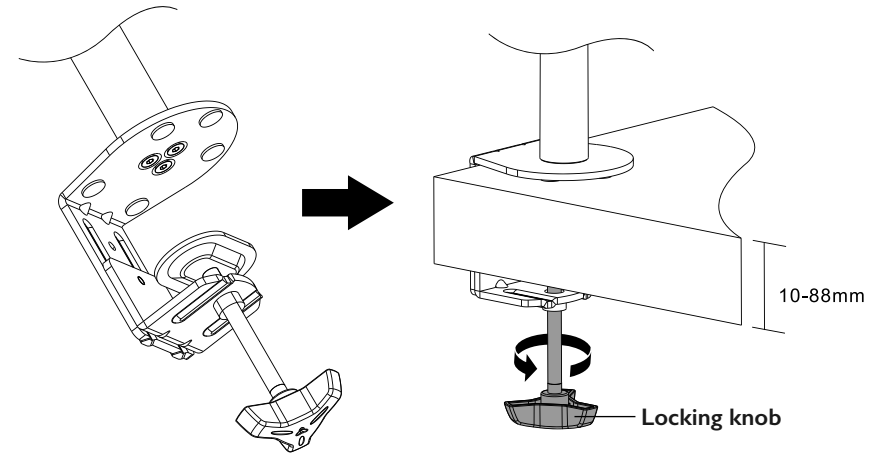

Option B - Grommet mount

1. Pull apart the C-clamp base by loosening the two screws with the allen wrench.
2. Next, with a phillips screwdriver, separate the curved clamping plate from the threaded bolt by holding steady the locking knob.

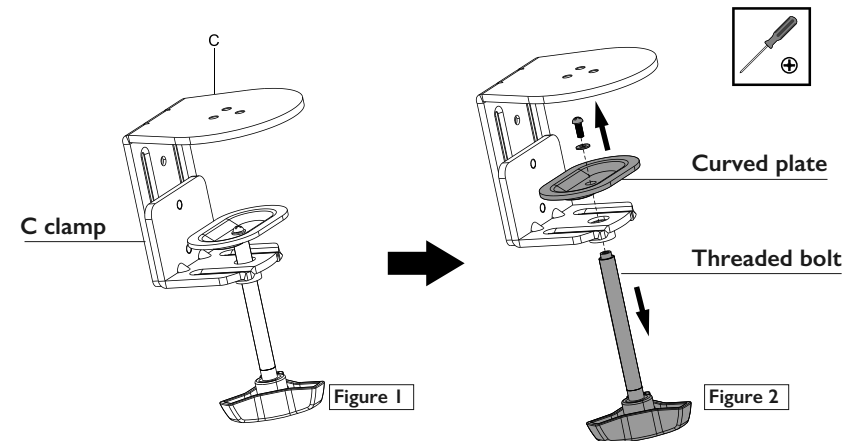

3. Attach the supplied flat clamping plate to the threaded bolt, and then fix the five rubber pads beneath the grommet base also included in the kit.

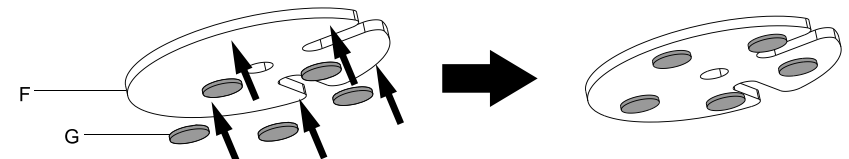

- Then, connect the grommet base tab to the groove on the shaft edge. Place the shaft and grommet base assembly on top of the cable opening, making sure the bolt hole is aligned right at the center.
- From underneath the work surface, pass the bolt with the flat clamping plate and thread it into the vertical assembly (shaft)

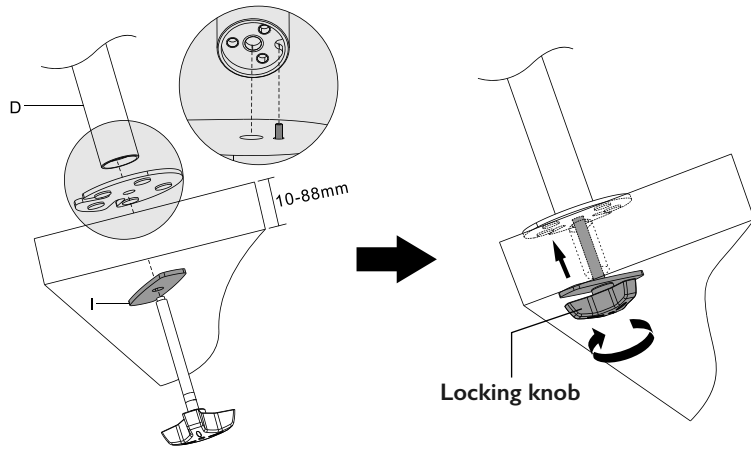

- Fully tighten the locking knob until it is securely mounted to your desk surface.

6. Final desktop assembly

- Once you have completed the installation steps described above, insert the cable clip on the shaft.
- Slide the mounting arm onto the shaft and tighten the screw at the desired height.

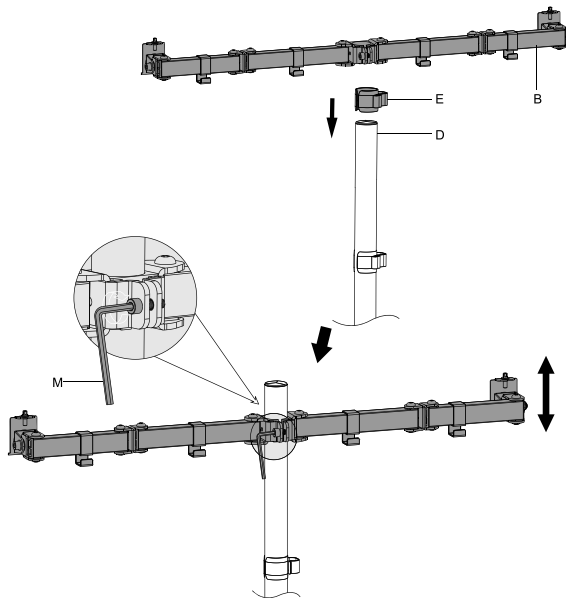

- Now carefully slide both monitors with the plate attached into the matching end of the dual mounting arm. Fasten the monitor to the arm with the plastic washers and screws provided.

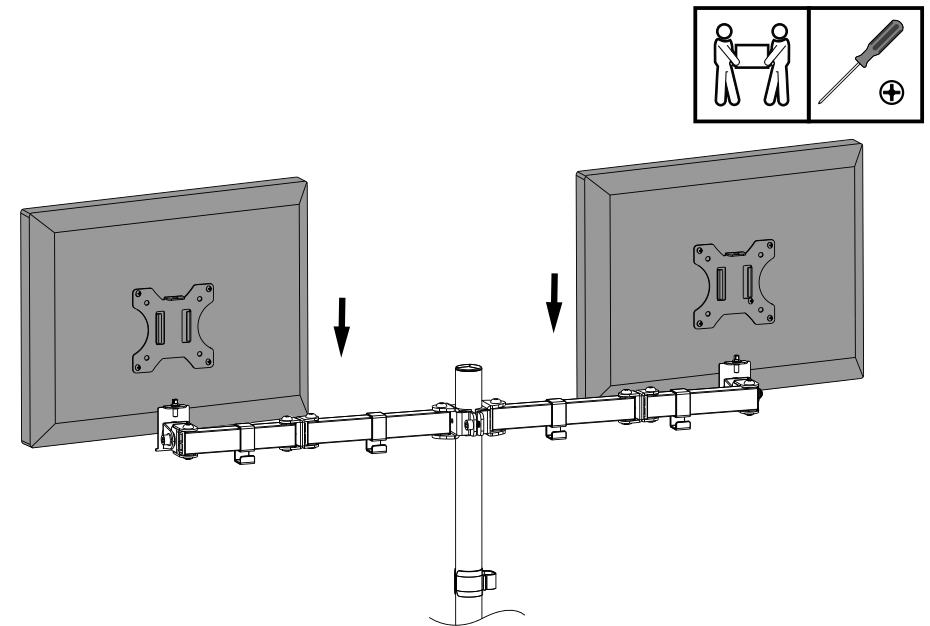

- Route the monitor and power cables through clips as shown.

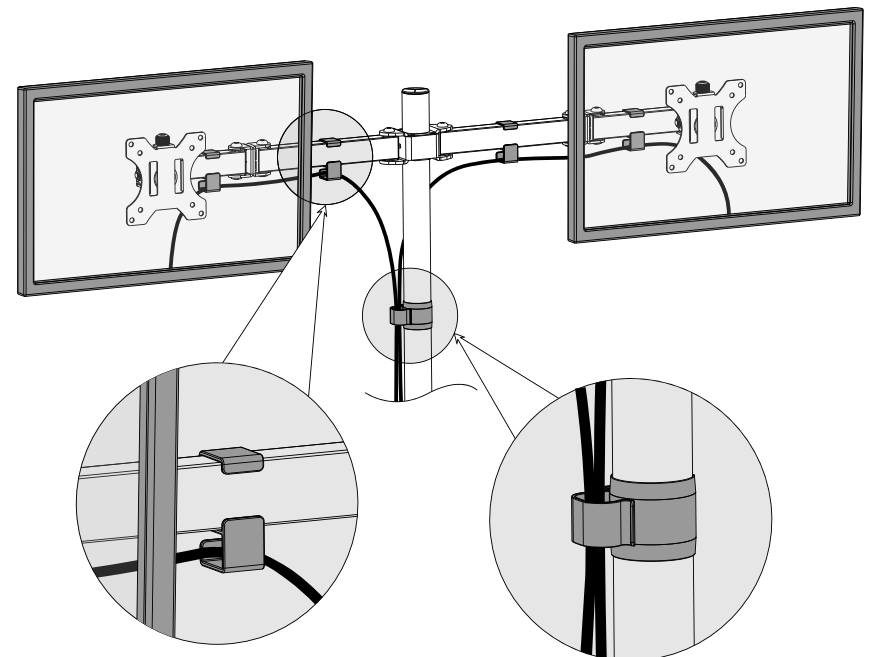

5. Now you can adjust the vertical (tilt) and horizontal (swivel) action of the mount.

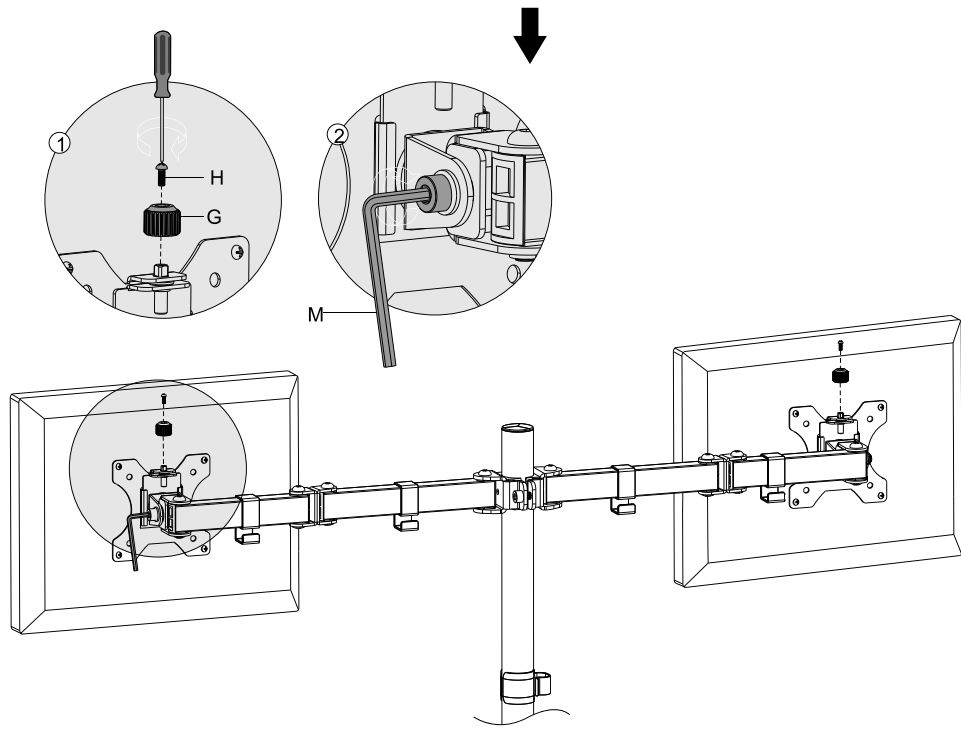

6. Also position the both ends of the arm in a straight line, as shown below.

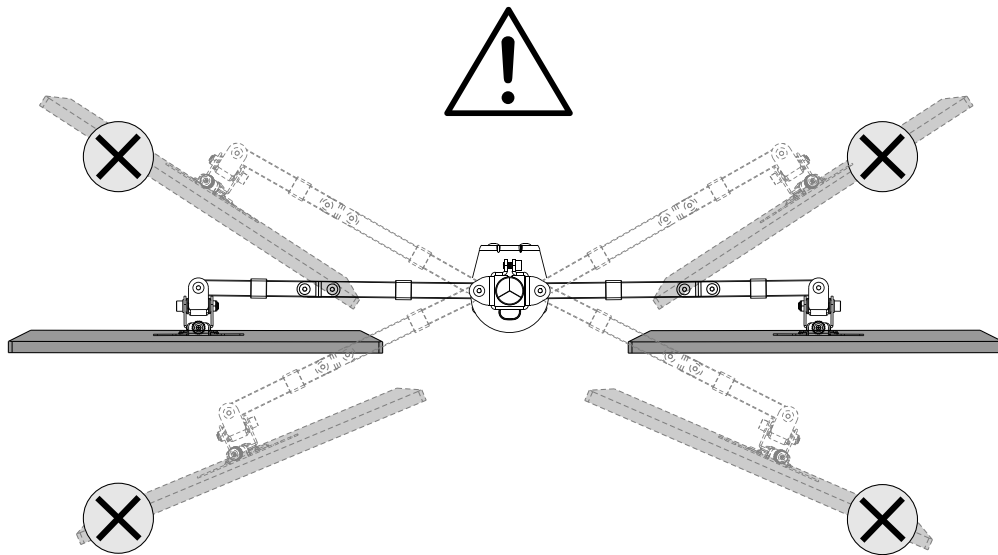

7. Fully tighten the screws of the joints when the optimal viewing angle is reached. The monitor can be also rotated for portrait or landscape orientation, or anything in between.

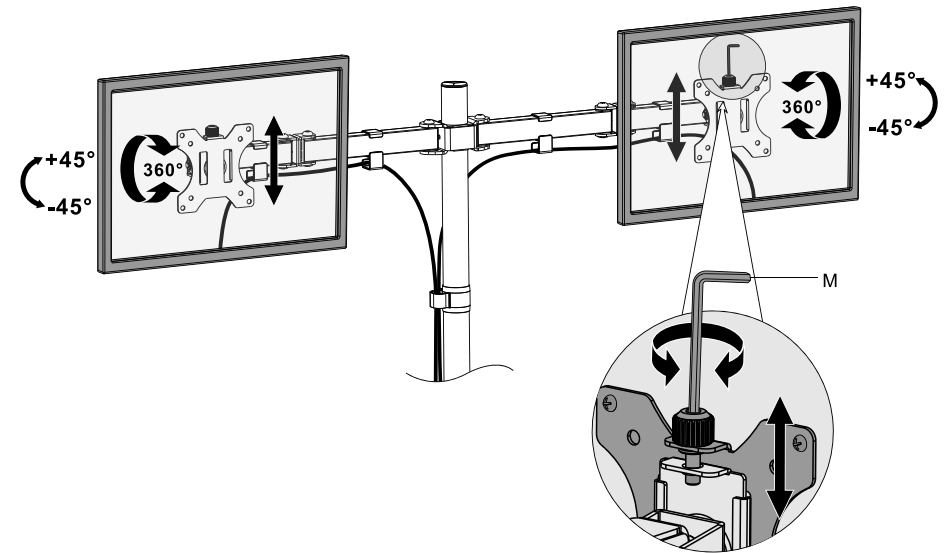

8. Finally, place the wrenches in the tool holder when not in use.

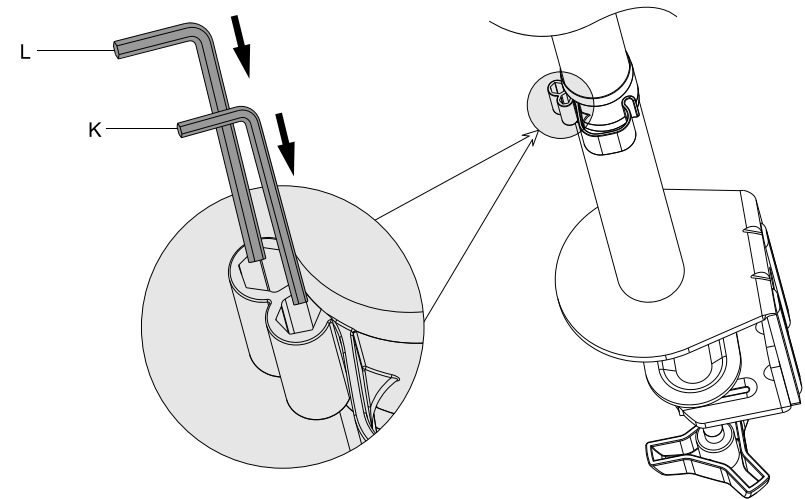

Notes
